

PIAA 220R

Installation Instructions

Thank you very much for purchasing PIAA product. Please read this instruction manual thoroughly for proper use of the product. After completing your installation, keep this manual for future reference.

CAUTION WARNING

The ● marks indicated in this manual are cautionary points related to the installation of the product. To ensure safe and secure installation of the product, please follow these points closely.

To user

... Please keep this manual and a receipt with the name of the shop where purchased. When giving this product to a third party, always include this manual together with the product.

To shop owners installing the product

... After installation of the product, make sure the customer is provided with this owner's manual.

Please read the cautionary points before installation to ensure safe utilization of the product.

WARNING

- The lamp becomes hot when turned on. When parking your vehicle near flammable items, turn off the lamp as it may catchfire.
- Do not look directly into the light. Doing so may cause eye irritation or visual impairment.

CAUTION

- The lamp and the switch harness are intended for motorized vehicle use only. Do not use for any other purpose.
- This lamp is intended for use in rain (day or night), during foggy or snowy conditions where visibility is hampered. Do not use during normal driving conditions.
- Do not operate the switch while driving, unless allowed by local regulation.
- If the lamp is kept on when the engine is off, the lamp will consume electricity from the battery.
- Make sure the lamp is installed securely before driving the vehicle. If a problem is found, immediately stop the vehicle and make necessary repair.
- Check for any loose screws that holds the lamp in place before driving. If you find any loose screws or bolts, tighten them securely.
If you notice a loose part while driving, inspect the section immediately and make necessary adjustments.
- Avoid repeatedly turning the lamp on and off as it may reduce the overall life of the LED.
- Some vehicles produce a high voltage electric charge when the engine is started. To avoid loading surge voltage to the lamp, turn off the lamp when starting engine.
- Do not disassemble the lamp or the switch harness as it may cause malfunction.
- If the lamp and/or the switch harness is removed and set aside for safekeeping, clean all dust or grime and store in a place free of moisture.
- If the lens is cracked or damaged in any way, verify whether there is any damage to the harness. If there is any damage to the cord covering, immediately replace the harness unit.

Please read the installation procedures thoroughly beforehand.

CAUTION

- In order for the lamp to safely perform at its full potential, use the relay harnesses that comes with your PIAA light kit.
- All work procedures should be carried out in a location with adequate space. Set the vehicle's transmission to parking position. Turn off the engine and apply the parking brake.
- Make sure the engine compartment is adequately cool before starting work. Do not begin work if engine parts such as radiator, oil-cooler or turbo parts are still hot.
- Do not add additional holes to the main body of the lamp. Do not apply adhesives or stickers to the lamp parts.
- Do not modify the lamp harness or the switch harness in any way. Such modifications may cause overheating or short circuit. It may cause the vehicle to catch fire. PIAA will not be liable for any damage caused by such modifications.
- When removing the battery terminals, do not touch the (-) and (+) terminals simultaneously. An electrical shock may occur. Wear rubber gloves when carrying out work procedures.
- Make sure the (-) and (+) terminals do not make contact with metal. It can be extremely dangerous if a short circuit occurs.
- Make sure all bolts are tightly secure. If there are any loose bolts, tighten them accordingly.
- After installing the lamp, adjust the lamp so the beam illuminates at least 40m in front of the vehicle. Also, adjust the lamp slightly aside so that it does not shine directly into the eyes of the opposing vehicle's driver. (as traffic laws stipulate -refer to p.7 for adjustment procedures)
- When the battery terminal is removed, memory related to the clock, radio, audio system etc. will be affected. After all work procedures are completed, reset to the original settings. (For adjustment procedures refer to your vehicle's instruction manual)

Caution Regarding Wiring / Please read thoroughly

WARNING

- When installing the wiring harness, strictly follow the cautionary points mentioned below. Incorrect or faulty wiring may cause the lamp to operate incorrectly. In some cases, it may cause the vehicle to catch fire.

CAUTION

- Before starting installation, always remove the (-) and (+) terminals. Always remove the (-) terminal first and make sure a short circuit does not occur.
- When removing the battery terminals, always turn the key to OFF and remove the key. Turn off all other electrical units off such as the light switch.
- When removing the battery terminals, if a cord (for an electrical unit) is connected, wind a length of vinyl tape around the (-) and (+) terminals to clearly identify them.
- Verify the (+) terminal (white) and earth (black) before connecting.
- Do not obtain (+) voltage from the alternator.
- Install the switch harness in a position where it will not make contact with any high temperature parts such as the engine, radiator or engine compartment.
- Arrange the switch harness so that it does not make contact with moving parts.
- If the switch harness makes contact with a part of the engine, apply heat-resistant cushioned tape around the harness.
- Make sure the harness does not sag. Use a harness band or vinyl tape to secure the harness to the intended position.
- Before connecting lamp wires to the battery, verify the wiring arrangement.
- When connecting the battery terminal and or other electrical units, do not mistake the (-) and (+) terminals. Always start with the (+) terminal.
- After all wiring is complete, confirm that it works properly. If it fails to activate, refer to "8 Troubleshooting" section of this manual.

Product Details

※ Verify all the parts are included. If a part is missing, please contact your local distributor.

Two Lamps

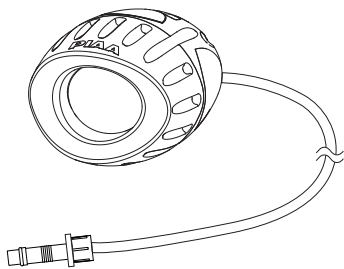

One Controller harness set

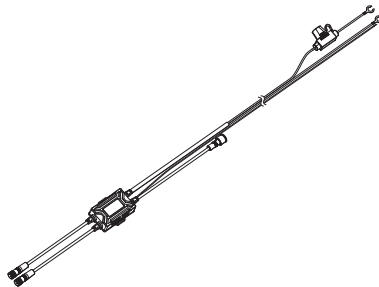

One Switch harness set

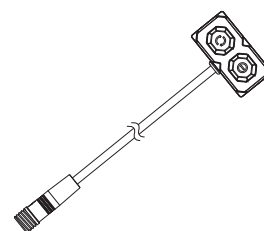

Two Lamp brackets

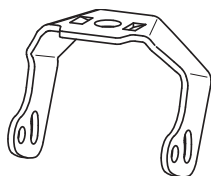

Eight Hexagon socket head bolts

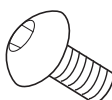

Eight Spring washers (small)



Two Hex bolts

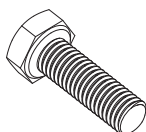

Two Nuts (large)



Two Spring washers (large)



Two Flat washers (large)



One Handle fixing bracket

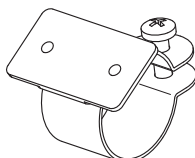

One Mirror fixing bracket A

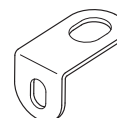

One Mirror fixing bracket B

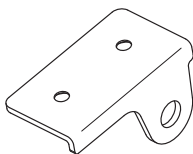

One Hex cap bolts



nut (small)



One Flat washer (small)



One Hexagonal wrench (small)

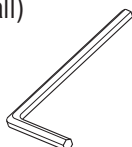

One Hexagonal wrench (large)

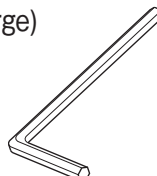

Ten Wire ties

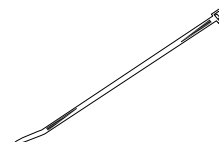

【1】 Preparation for lamp installation

Attach the plastic cover

Choose one of 4 positions of the bracket shown below.

Remove the rubber caps at the points to be used for installation.

( : Positions of rubber caps)

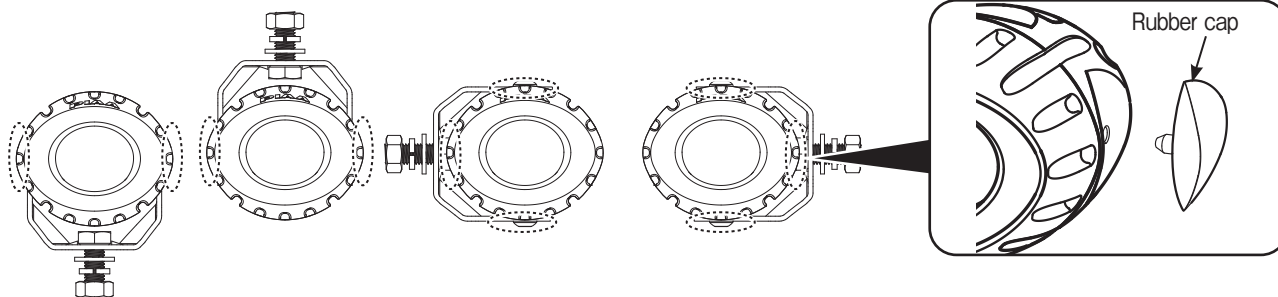

Make sure the installation position is correct and the logo will not be upside down.



Assemble the bracket

Insert Hex bolt through the bracket first.

Next, attach the bracket to the lamp using the hexagon socket head bolt, small spring washer. Be sure to verify the direction of the bracket "front"-"back" is correct.

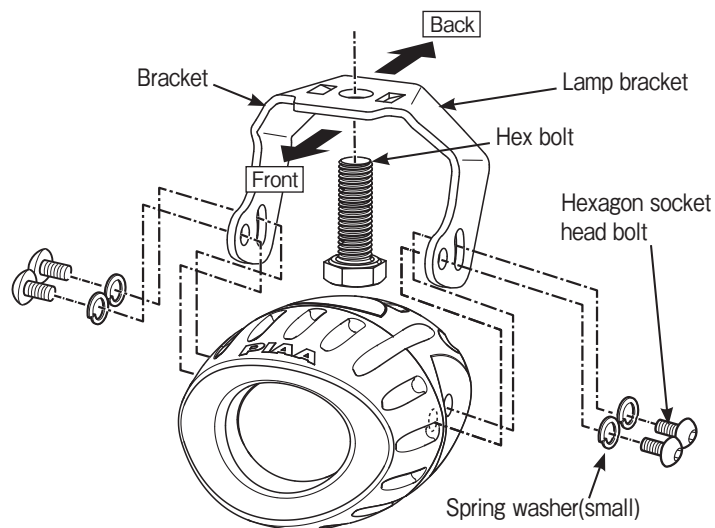

[2] Lamp installation

For lamp installation, a hole with a diameter of 8mm is required. Make necessary preparation such as installation of lamp bracket.

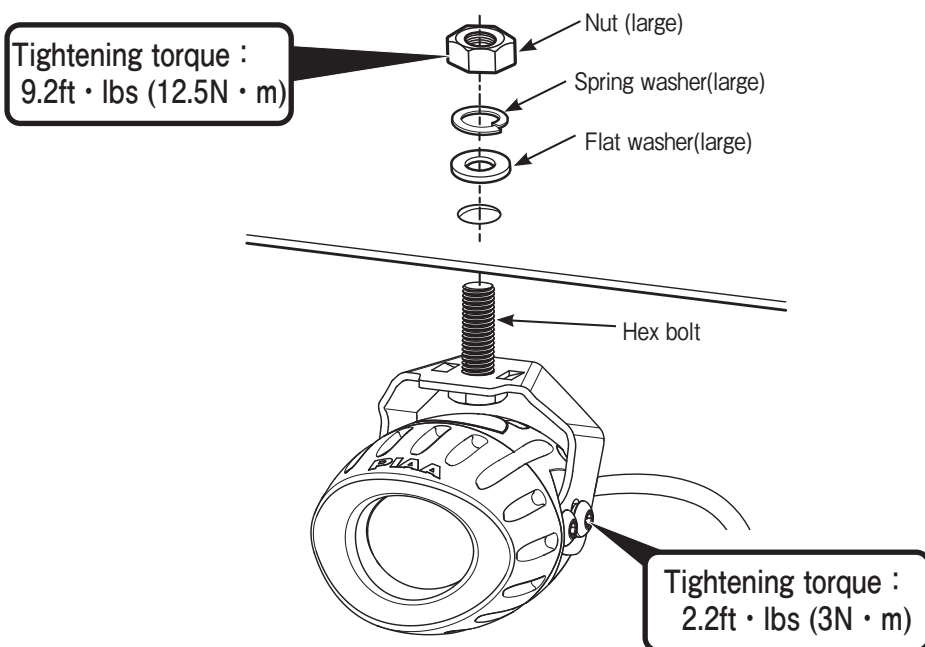

CAUTION

- The lamp is designed to illuminate with the "PIAA" logo facing upwards.
- The lamp should be mounted on an area sufficient to support its size and weight.
- Failure to do so may result in excess vibration leading to shorter life and/or physical damage to the lamp or to your vehicle.
- Do not attempt to install the lamp directly to any plastic part of the vehicle's body.
- If the lamp needs to be installed on a plastic reinforcement material, the lamp should be placed on both sides of the plastic part.
- When installing, make sure the lamp body, lens and rim are not touching any plastic parts. Such plastic parts might deform.
- Torque specification on the base mounting nut is 9.2ft · lbs (12.5N · m)
- Torque specification on the bracket mounting bolt is 2.2ft · lbs (3N · m)

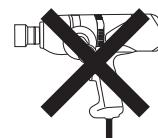

Impact wrench

[3] Switch bracket Installation

- First remove the switch fixing screw attached to the switch harness set.
- When fixing the switch to the handlebar.

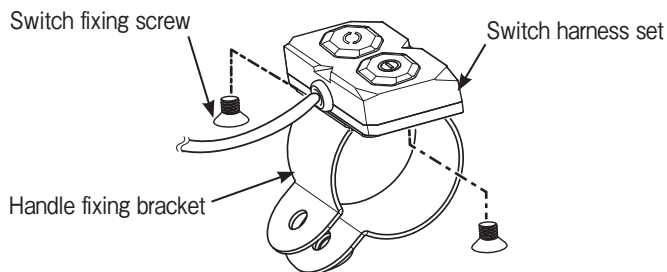

- When the switch is installed by co-tightening to the mirror.

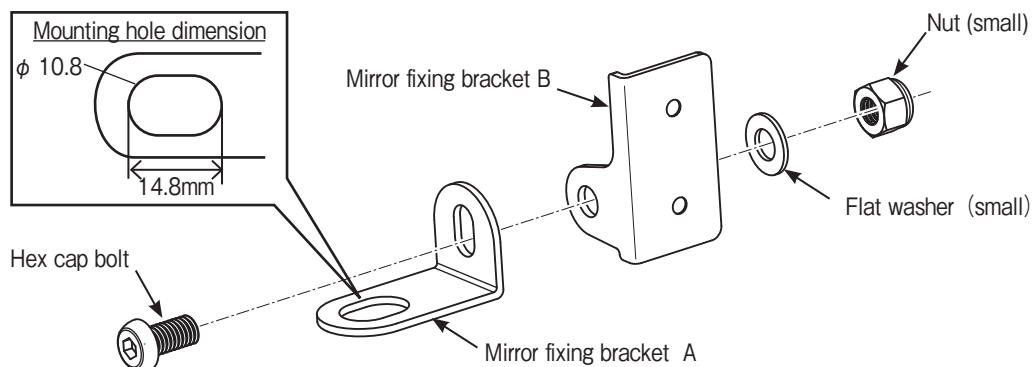

■ The height of bracket B can be adjusted by the bolt position and the orientation of bracket A.

Example

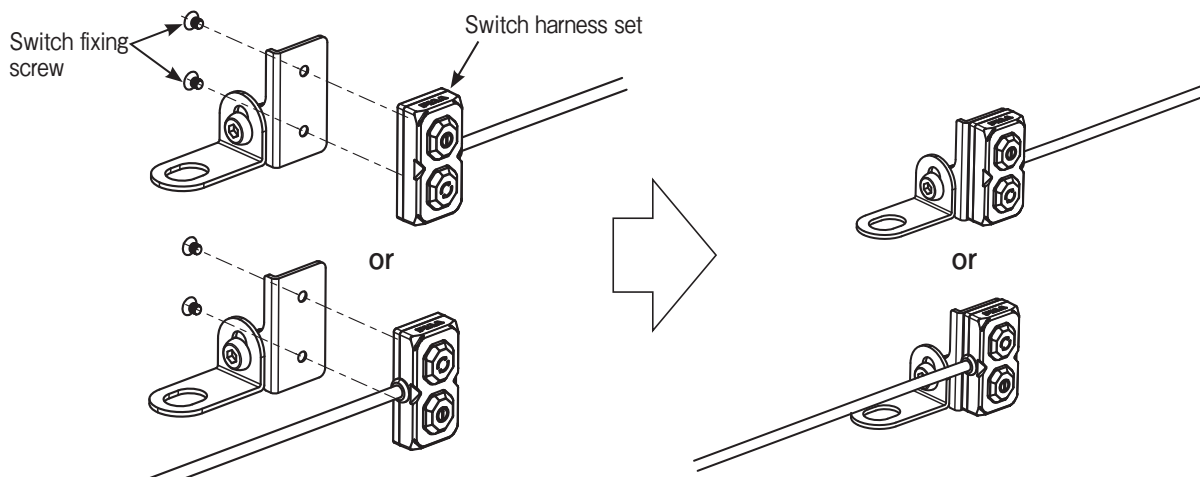

[4] Switch Harness Installation Sequence

The numbers shown in the figure below indicates the sequence each parts should be installed.

2 Remove the (+) terminal from the battery.

1 Remove the (-) terminal from the battery.

10 Attach the (+) terminal to the battery.

9 Attach the (-) terminal to the battery.

7 Attach the (+) cord to the (+) battery.

6 Attach the (-) cord to the body earth or to the (-) battery.

4 Connect to the switch harness connector.
 ※ If the length is not enough, use the extension harness sold separately. (LR-52)

8 Connect to the vehicle's harness that is powered when the ignition is turned ON.

5 Connect to the lamp harness.
 ※ If the length is not enough, use the extension harness sold separately. (LR-52)

3 When fixing the switch to the handlebar

Switch harness set
 Handle fixing bracket
 Screw

When the switch is installed by co-tightening to the mirror

Left mirror
 Switch harness set

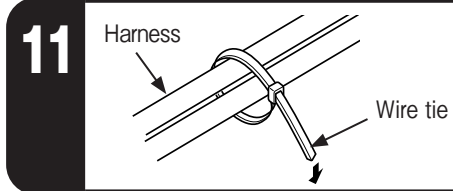
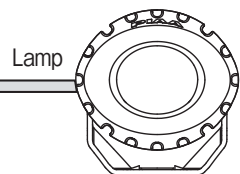
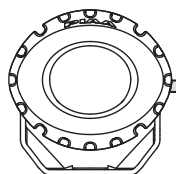
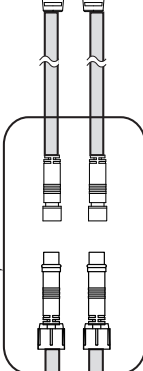
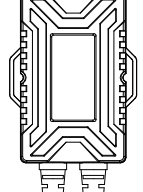
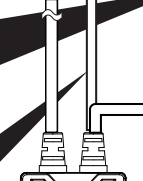
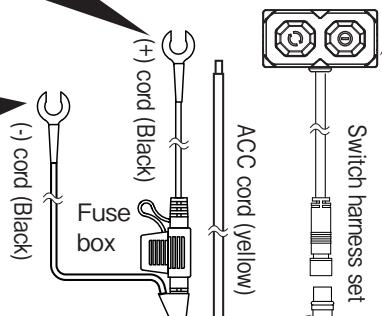
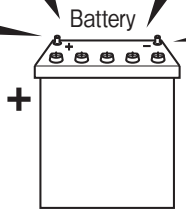

11 After the lamps are installed, verify the lamp and switch harnesses does not make contact with the engine's moving parts or sections that emit high heat. Use the wire tie included (Item 5) and secure the lamp and switch harnesses with the vehicle's original wires.

【5】 Lighting pattern

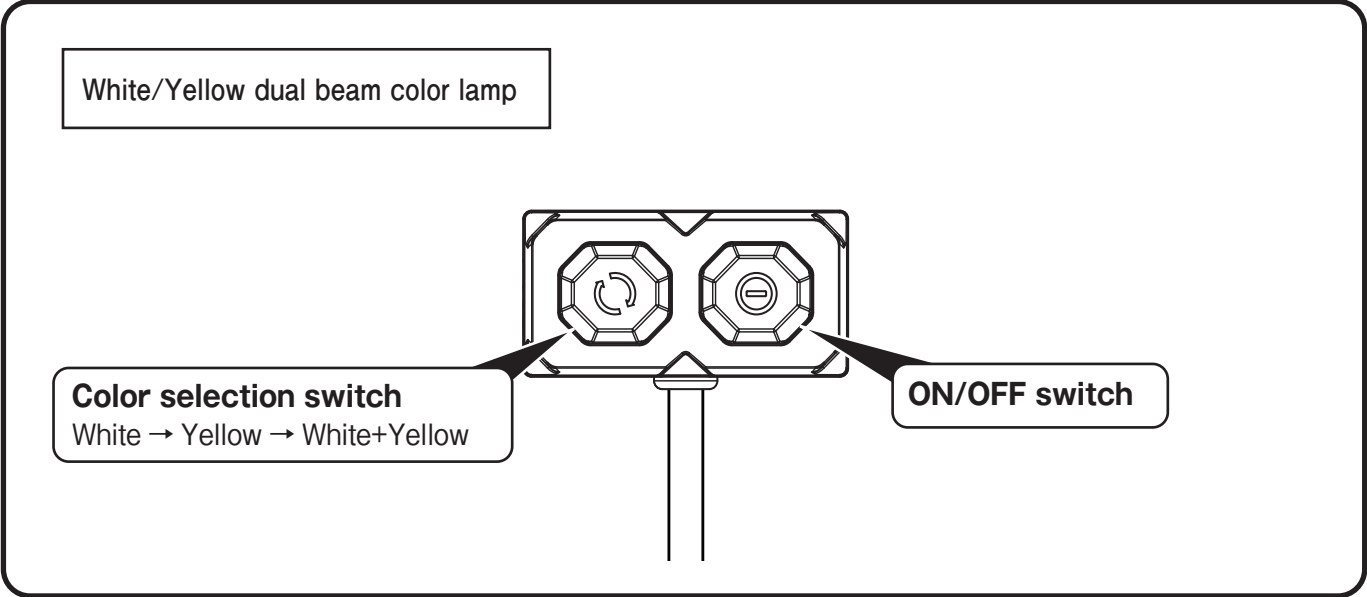

【6】 Driving Light Aiming

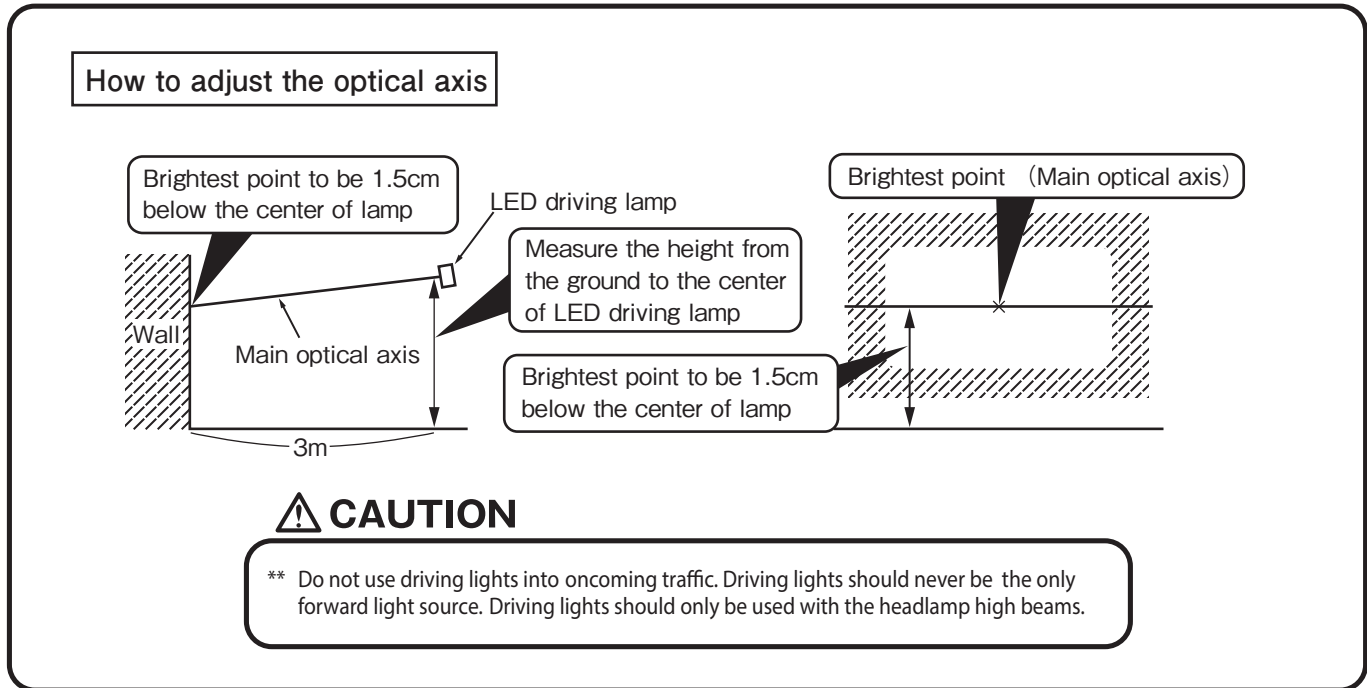

Troubleshooting.....Verify each section according to the following.

- 1 After installation, if the lamp does not activate
 - Check the wiring and make sure there are no faulty or incorrect connections .
- 2 If the LED suddenly fails to light up ...
 - Check the fuse located on the vehicle's wiring system. If the fuse is burned out, read below [3] Before replacing the fuse, then replace with an equal ampere fuse.
 - There may be cases where each terminal related to specific sections may be incorrectly connected. Check for any loose wires and also for dirt or grime.
 - Check if the switch unit operates normally. If not, replace the switch unit.
- 3 Before replacing the fuse
 - A short circuit may have occurred. Check the wiring system. If any type of damage is found, replace the wiring system. Non replacement may pose potential danger. Short circuits are mainly caused when wires are incorrectly connected or when there is a gap in the sleeve connected to the lamp harness.

PIAA LIMITED WARRANTY**REPAIR AND REPLACEMENT**

If a PIAA product is suspected of being defective, it must be submitted freight prepaid, to either an authorized dealer or distributor for warranty inspection within the 2 year warranty period. The receipt or other proof of purchase and a description of the problem must be included. The returned product will be inspected. If the product is found to be defective and covered by this Limited Warranty, the sole remedy is repair or replacement, at PIAA's option. A repaired or replacement product will be shipped back at no charge. Removal, installation, or reinstallation costs are not covered by this 2 year Limited Warranty.

EXCLUSIONS

This Limited Warranty specifically excludes defects resulting from misuse, abuse, neglect, alteration, modification, improper installation, unauthorized repairs, submersion, theft, vehicle crash, or by any other type of impact. Except for the Limited Warranty stated above, there are no warranties of PIAA products or any part thereof, whether express or implied. Any implied warranty of merchantability or any warranty of fitness for a particular purpose is expressly disclaimed. Some states do not permit the disclaimer of implied warranties.

LENS CRACKS

Crash or impact damage is not covered. This can be determined by a chip or scrape on the lens or the housing. Stress cracks sometimes occur when the lens is subjected to sudden and extreme temperature changes. A stress crack has no chip or other sign of impact. Stress cracks are covered under warranty.

EXCLUSION OF DAMAGES

In no event shall PIAA be liable for any damages whatsoever (including, without limitation, consequential damages, incidental damages, or damages for loss of use, loss of business profits, business interruption, loss of business information, loss of time, inconvenience, or other losses) arising out of the use, misuse, or inability to use a PIAA product. PIAA reserves the right to change the design of its products without any obligation to modify any previous product.

PIAA CORPORATIONwww.piaa.co.jpwww.piaa.com